

Selection guides page 5/2

- Osiconcept®: Offering Simplicity through Innovation page 5/6

Osiswitch® Universal, Osiconcept®

- Miniature design, metal, type XCM D page 5/8
 - Pre-cabled page 5/10
 - Integral or remote connector page 5/14
 - Variable composition page 5/20
 - Separate components page 5/22
- Compact design, metal, type XCK D - Presentation page 5/28
 - Complete units with 1 ISO M16 x 1.5 cable entry page 5/30
 - Integral M12 connector page 5/34
- Compact design, plastic, type XCK P - Presentation page 5/28
 - Complete units with 1 ISO M16 x 1.5 cable entry page 5/36
 - Integral M12 connector page 5/40
- Compact design, plastic, type XCK T - Presentation page 5/28
 - Complete units with 2 ISO M16 x 1.5 cable entries page 5/42
- Compact design, types XCK D, XCK P and XCK T
 - Variable composition page 5/44
 - Adaptable sub-assemblies: bodies with contacts page 5/46

Osiswitch® Optimum

- Miniature design, plastic, type XCM N - Presentation page 5/24
 - Complete units, pre-cabled page 5/26
- Compact design, plastic, type XCK N page 5/50
 - Complete units with 1 cable entry page 5/52
- Compact design, with reset, type XCN R page 5/56
 - Complete units with 1 cable entry page 5/58

Osiswitch® Application, with reset

- Compact design, metal, type XCD R page 5/60
 - Complete switches with 1 cable entry page 5/62
- Compact design, plastic, type XCP R page 5/60
 - Complete switches with 1 cable entry page 5/64
- Compact design, plastic, type XCT R page 5/60
 - Complete switches with 2 cable entries page 5/66

Osiswitch® Classic

- Metal, type XCK M page 5/68
 - Complete switches with 3 ISO M20 x 1.5 cable entries page 5/70
- Metal, type XCK L page 5/68
 - Complete switches incorporating cable gland page 5/72
- Metal, 2 x 2-pole contacts, type XCK ML page 5/68
 - Complete switches with 3 ISO M20 x 1.5 or Pg 13 cable entries page 5/74



Osiswitch® Classic (continued)

- Metal, types XCK M and XCK L
 - Variable composition page 5/76
 - Adaptable sub-assemblies page 5/78
- Metal, type XCK J page 5/84
 - Complete switches
 - Fixed body with 1 ISO M20 x 1.5 cable entry page 5/86
 - Fixed body with 1 Integral M12 connector page 5/90
 - Fixed body with 1 Integral 7/8" 16 UN connector page 5/92
 - Variable composition: standard bodies, fixed or plug-in page 5/94
 - Adaptable sub-assemblies
 - Bodies and contact blocks page 5/96
 - For low temperature applications (- 40 °C) page 5/106
 - For high temperature applications (+ 120 °C) page 5/109
- Plastic, double insulated, type XCK S
 - Complete switches with 1 ISO M20 x 1.5 cable entry page 5/112
 - Variable composition page 5/116
 - Adaptable sub-assemblies: bodies, contact blocks page 5/118

Osiswitch® Classic: Applications

- For hoisting and mechanical handling applications, types XCR and XCK MR page 5/124
- For conveyor belt shift monitoring, type XCR T page 5/126
- For materials handling applications, type XC1 AC page 5/132
- For very severe applications, type XC2 J page 5/138
 - Complete switches, fixed body page 5/140
 - Fixed or plug-in body, variable composition page 5/142
 - Adaptable sub-assemblies page 5/143

Osiswitch® miniature snap switches

- Subminiature design, DIN 41635 B format, sealed page 5/156
- Sub-subminiature design, DIN 41635 D format page 5/157
- Miniature design, DIN 41635 A format page 5/158
- Sealed design, pre-cabled page 5/160
- General page 5/162

Limit switches for safety solutions using Preventa

- Miniature design, metal, type XCS M page 5/164
- Guard switches, plastic, types XCS PA, XCS TA and XCS TE page 5/166
- Safety switches, types XCS PL, XCS TL, XCS PR and XCS TR page 5/168
- Guard switches, metal, types XCS A, XCS B, XCS C and XCS E page 5/170
- Coded magnetic switches, types XCS DMC, DMP and DMR page 5/172
- Coded magnetic systems page 5/184

Osiswitch® limit switches

- General page 5/192
- Substitution table page 5/200



Design		Miniature Osiconcept		Compact Osiconcept	
Enclosure		Metal		Plastic, double insulated	
Features		Fixing by the body or by the head			
Osiconcept modularity		Head, body and connection modularity			Head and body modularity
CENELEC conformity		–		EN 50047	EN 50047 compatible
Body dimensions (w x h x d) in mm		30 x 50 x 16	31 x 65 x 30		58 x 51 x 30
Head		Linear movement (plunger) Rotary movement (lever) Rotary movement, multi-directional Same heads for ranges XCM D, XCK D, XCK P and XCK T			
Contact blocks	2 snap action contacts with positive opening operation	N/C + N/O; N/C + N/C			N/C + N/O
	3 snap action contacts with positive opening operation	N/C + N/C + N/O		N/C + N/C + N/O; N/C + N/O + N/O	–
	4 snap action contacts with positive opening operation	N/C + N/C + N/O + N/O –			
	2 slow break contacts with positive opening operation	N/C + N/O break before make	N/C + N/O break before make; N/O + N/C make before break; N/C + N/C simultaneous		
	2 slow break contacts	–		N/O + N/O simultaneous	
	3 slow break contacts with positive opening operation	N/C + N/C + N/O break before make	N/C + N/C + N/O break before make; N/C + N/O + N/O break before make		–
Insulation voltage (Ui) / thermal current (Ithe)		Pre-cabled 2 contacts: 400 V/6 A 3 contacts: 400 V/4 A 4 contacts: 400 V/3 A	Screw terminal 2 contacts: 500 V/10 A 3 contacts: 400 V/6 A		Screw terminal 2 contacts: 500 V/10 A
		Connector Integral M12, 4-pin: 250 V/3 A Integral M12, 5-pin: 60 V/4 A Remote 7/8" 16UN: 250 V/6 A	Connector Integral M12, 5-pin: 60 V/4 A	Connector Integral M12, 4-pin: 250 V/3 A	–
Degree of protection IP/IK		IP 66, IP 67, IP 68, IK 06	IP 66, IP 67, IK 06	IP 66, IP 67, IK 04	
Connection	Screw terminals	–		1 entry for ISO M16 or M20, Pg 11, Pg 13 cable gland or 1/2" NPT, PF 1/2	2 entries for ISO M16 or Pg 11 cable gland or 1/2" NPT (using adaptor)
	Pre-cabled	Yes –			
	Connector	Integral or remote M12 or remote 7/8" 16UN	Integral M12		–
Type reference		XCM D	XCK D	XCK P	XCK T
Page(s)		5/10	5/30 and 5/34	5/36 and 5/40	5/42

5

Miniature Optimum		Compact Optimum		Compact Optimum: with reset		Compact Application: with manual reset	
							
Plastic, double insulated				Metal		Plastic, double insulated	
Fixing by the body or by the head		Fixing by the body					
-		-					
-		EN 50047		-		-	
30 x 50 x 16		31 x 65 x 30				58 x 51 x 30	
Linear movement (plunger) Rotary movement (lever) Rotary movement, multi-directional		Linear movement (plunger) Rotary movement (lever)		Linear movement (plunger) Rotary movement (lever) Same heads for ranges XC DR, XC PR and XC TR			
N/C + N/O		N/C + N/O; N/C + N/C				N/C + N/O	
-		Other contacts (1): For complete switches with the following 2-pole contacts: N/C + N/C simultaneous, slow break, N/O + N/C make before break, slow break, N/O + N/O simultaneous, slow break.				-	
-		For complete switches with the following 3-pole contacts: N/C + N/O + N/O snap action, N/C + N/C + N/O snap action, N/C + N/C + N/O break before make, slow break, N/C + N/O + N/O break before make, slow break.				-	
-						N/C + N/O break before make	
-						-	
-						-	
Screw terminal 2 contacts: 400 V/6 A		Screw terminal 2 contacts: 500 V/10 A					
-		-					
IP 65, IK 04						IP 66, IP 67, IK 04	
-		1 entry for ISO M20 or Pg 11 cable gland		1 entry for ISO M20 or Pg 13 cable gland or 1/2" NPT		2 entries for ISO M16 or Pg 11 cable gland or 1/2" NPT (using adaptor)	
-		Other cable entries (1): ISO M16 x 1.5 or PF 1/2 (G 1/2)					
Yes		-					
-		-					
XCM N	XCK N	XCN R	XCD R	XCP R	XCT R		
5/26	5/52	5/58	5/62	5/64	5/66		

(1) please consult your Regional Sales Office.

5

Design		<i>Classic</i>																																						
Enclosure		Metal		Plastic, double insulated																																				
Features		–		Fixed or plug-in body, -40 °C or +120 °C																																				
Variable composition switches		Head + Body + Operator																																						
CENELEC or DIN conformity		–																																						
Body dimensions (w x h x d) in mm		63 x 64 x 30	52 x 72 x 30	40 x 77 x 44 42.5 x 84 x 36	40 x 72.5 x 36																																			
Head		Linear movement (plunger) Rotary movement (lever) Rotary movement, multi-directional																																						
Contact blocks		<table border="1"> <tr> <td>2 snap action contacts with positive opening operation</td> <td>N/C + N/O; N/C + N/C</td> <td>N/C + N/O</td> <td colspan="2">N/C + N/O; N/C + N/C</td> </tr> <tr> <td>3 snap action contacts with positive opening operation</td> <td colspan="4">N/C + N/C + N/O; N/C + N/O + N/O</td> </tr> <tr> <td>C/O snap action contacts</td> <td colspan="2">–</td> <td colspan="2">2 C/O</td> </tr> <tr> <td>C/O slow break contacts</td> <td colspan="4">–</td> </tr> <tr> <td>2 slow break contacts with positive opening operation</td> <td colspan="4">N/C + N/O break before make N/O + N/C make before break N/C + N/C simultaneous</td> </tr> <tr> <td>2 slow break contacts</td> <td colspan="4">N/O + N/O simultaneous</td> </tr> <tr> <td>3 slow break contacts with positive opening operation</td> <td colspan="4">N/C + N/C + N/O break before make N/C + N/O + N/O break before make</td> </tr> </table>				2 snap action contacts with positive opening operation	N/C + N/O; N/C + N/C	N/C + N/O	N/C + N/O; N/C + N/C		3 snap action contacts with positive opening operation	N/C + N/C + N/O; N/C + N/O + N/O				C/O snap action contacts	–		2 C/O		C/O slow break contacts	–				2 slow break contacts with positive opening operation	N/C + N/O break before make N/O + N/C make before break N/C + N/C simultaneous				2 slow break contacts	N/O + N/O simultaneous				3 slow break contacts with positive opening operation	N/C + N/C + N/O break before make N/C + N/O + N/O break before make			
2 snap action contacts with positive opening operation	N/C + N/O; N/C + N/C	N/C + N/O	N/C + N/O; N/C + N/C																																					
3 snap action contacts with positive opening operation	N/C + N/C + N/O; N/C + N/O + N/O																																							
C/O snap action contacts	–		2 C/O																																					
C/O slow break contacts	–																																							
2 slow break contacts with positive opening operation	N/C + N/O break before make N/O + N/C make before break N/C + N/C simultaneous																																							
2 slow break contacts	N/O + N/O simultaneous																																							
3 slow break contacts with positive opening operation	N/C + N/C + N/O break before make N/C + N/O + N/O break before make																																							
Insulation voltage (Ui) / thermal current (Ithe)		Screw terminal 2 contacts: 500 V/10 A 3 contacts: 400 V/6 A																																						
Degree of protection IP/IK		IP 66, IK 06		IP 66, IK 07																																				
Connection		<table border="1"> <tr> <td>Screw terminals (entry for cable gland)</td> <td>3 entries for ISO M20 or Pg 11 cable gland or 1/2" NPT</td> <td>1 entry incorporating cable gland or tapped 1/2" NPT</td> <td>1 entry for ISO M20 or Pg 13 cable gland or 1/2" NPT</td> <td>1 entry for ISO M20 or Pg 13 cable gland</td> </tr> <tr> <td>Connector</td> <td colspan="2">–</td> <td>Integral M12 or 7/8" 16UN</td> <td>–</td> </tr> </table>				Screw terminals (entry for cable gland)	3 entries for ISO M20 or Pg 11 cable gland or 1/2" NPT	1 entry incorporating cable gland or tapped 1/2" NPT	1 entry for ISO M20 or Pg 13 cable gland or 1/2" NPT	1 entry for ISO M20 or Pg 13 cable gland	Connector	–		Integral M12 or 7/8" 16UN	–																									
Screw terminals (entry for cable gland)	3 entries for ISO M20 or Pg 11 cable gland or 1/2" NPT	1 entry incorporating cable gland or tapped 1/2" NPT	1 entry for ISO M20 or Pg 13 cable gland or 1/2" NPT	1 entry for ISO M20 or Pg 13 cable gland																																				
Connector	–		Integral M12 or 7/8" 16UN	–																																				
Type reference		XCK M	XCK L	XCK J	XCK S																																			
Page(s)		5/68	5/68	5/84	5/112																																			



Limit switches

Osiswitch® Classic, Application and Miniature snap switches

Application: for installations requiring electrical redundancy	Application: for lifting and materials handling equipment or very severe applications	Sub-miniature, miniature: applications requiring high precision and a low operating force	Applications: safety (1)		
			Limit switches	Coded magnetic switches, pre-cabled or with connector on flying lead	Coded magnetic system



Metal	Metal or polyester	Plastic	Metal or plastic	Plastic	
2 sets of contacts	–	Depending on type			
Head + Body + Operator	Fixed composition	Depending on type, fixed composition or contact and operator	–		
–	–	–	EN 50041 or EN 50047	–	
72 x 81 x 36	Depending on type	DIN 41635, depending on type	Depending on type	16 x 51 x 7 25 x 88 x 13 Ø 30, L 38.5	34 x 100 x 32
Linear movement (plunger) Rotary movement (lever)	–	Linear movement (plunger)	Linear movement (plunger) Rotary movement (lever) Actuator operated Spindle operated	–	
2 x N/C + N/O contact blocks	Depending on type	–	Depending on type: 2-pole, 3-pole or 4-pole contact blocks	Independent Reed type contacts operated by coded magnet. Must be used with a Preventa safety module. Depending on type: N/C + N/O (N/C staggered) N/O + N/O (1 N/O staggered) N/C + N/C + N/O (1 N/C staggered) N/C + N/O + N/O (1 N/O staggered) N/C + N/O (N/O staggered) N/O + N/O (1 N/O staggered)	Self-contained system not requiring use of safety module or non-magnetic slim 2 PNP type Solid-state outputs XCS DM4 : EDM function + 1 alarm output
–	Depending on type	1 single-pole contact	–		
–	Depending on type	–	–		
2 x N/C + N/O break before make contact blocks	Depending on type	–	–		
–	–	–	–		
–	–	–	–		
–	–	–	–		
Screw terminal 2 contacts: 500 V/10 A	Depending on type		–		
–	–		–		
IP 66, IK 06	Depending on type: IP 66, IK 05, IP 65, IK 05 or IP 54, IK 05	Depending on type		Depending on type: IP 66 and IP 67 or IP 67	Pre-cabled: IP 66, IP 67 and IP 69K Connector: IP 67
3 entries for ISO M20 or Pg 13 cable gland	Depending on type: 1 or 3 entries for ISO M20 or Pg 13 cable gland	Depending on type: by tags or pre-wired	Depending on type: entry for cable gland or pre-cabled	Depending on type: pre-cabled or with connector on flying lead	Depending on type: pre-cabled or with M12 connector (A coding)
–	–		–		
XCK ML	XCR, XCK MR, XC1 AC, XC2 J	XEP	XCS ●	XCS DMC XCS DMP XCS DMR	XCS DM3 XCS DM4
5/68	5/122, 5/132 and 5/138	5/156	5/164	5/174 and 5/175	5/184

(1) For further information, please refer to our "Safety solutions using Preventa" catalogue.

Limit switches

Osiswitch®

Osiconcept®: Offering Simplicity through Innovation

Principle

Osiconcept principle: innovation through modularity

■ The Miniature design XCM D and Compact design XCK D, XCK P and XCK T product range family benefits from Osiconcept: Offering simplicity through innovation.

■ A worldwide detection first for improving productivity.

A complete offer for resolving the most commonly encountered detection problems:

- product selection simplified,
- product availability simplified,
- installation and setting-up simplified,
- maintenance simplified.

Heads

■ A single metal operating head type for the Miniature design XCM D and Compact design XCK D, XCK P and XCK T ranges.

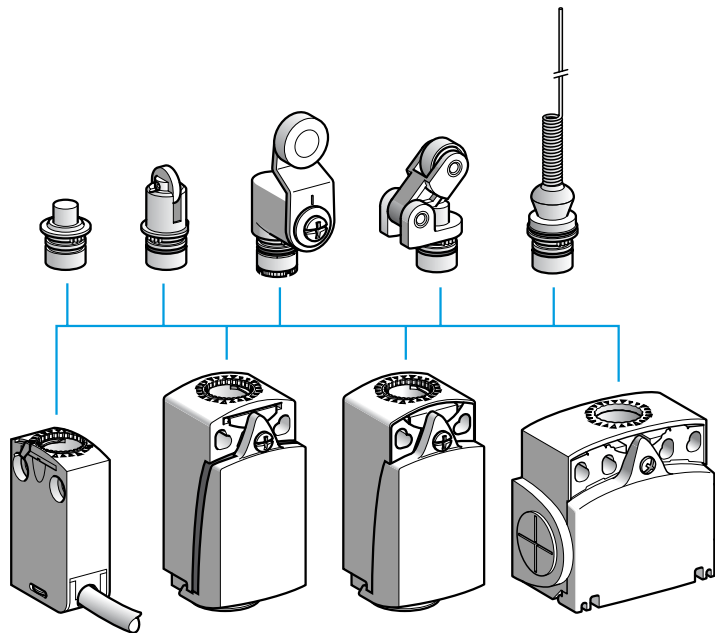

- Interchanging of heads achieved by simple operation of forked metal latch.
- Adjustable in 3 planes:

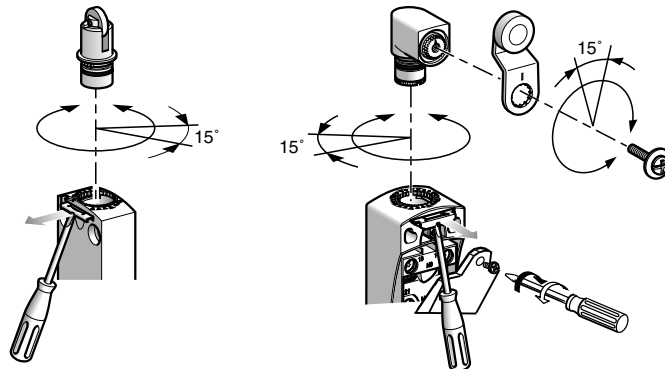

All the heads can be adjusted in 15° steps throughout 360°, in relation to the body.

All the levers can be adjusted in 15° steps throughout 360°, in relation to the horizontal axis of the head.

Principle (continued)

Cable entries

■ The cable entries for Compact design XCK D and XCK P switches enable: simple cabling due to unrestricted access to contacts,

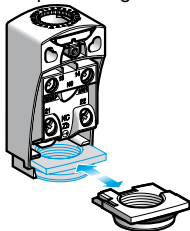

simple adaptation to the various worldwide markets:
- 6 models are available:



ISO M16 x 1.5
Pg 11



ISO M20 x 1.5
Pg 13
1/2" NPT
PF 1/2 (G 1/2)

Each model is available in metal or plastic, respectively suited for Compact design XCK D and XCK P.

Connection components

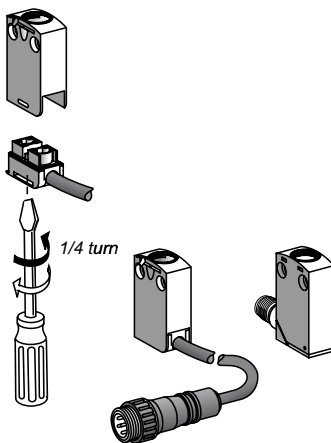

■ The miniature XCM D range allows interchangeability of these pre-cabled connection components: a 1/4 of a turn is all that is required for removing the connection component on XCM D bodies with 2 and 3 contacts, 6 alternative cable lengths are available as standard.

■ The miniature XCM D range also includes an integral or remote connector solution.

5

Contact block or body with contacts

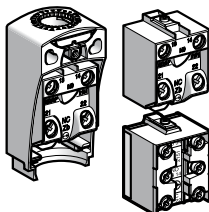

■ 2 and 3 snap action and slow break contact blocks, with positive opening operation, are interchangeable between the Compact design XCK D and XCK P and Classic XCK J, XCK S, XCK M and XCK L ranges.



■ For the Miniature design XCM D range, the contacts are an integral part of the body: 2 and 3 snap action and slow break contacts, with positive opening operation, and interchangeable connection component, 4 snap action contacts, with positive opening operation, with monolithic body and connection components.

Limit switches

Osiswitch® Universal, Osiconcept®
Miniature design, metal, type XCM D

■ XCM D
pre-cabled

□ With head for linear movement (plunger). Fixing by the body.

520341

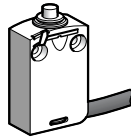

561279

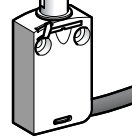

520343

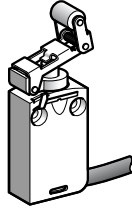

Page 5/10

□ With head for linear movement (plunger). Fixing by the head.

520344

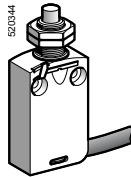

561280

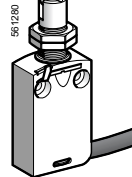

Page 5/10

□ With head for rotary movement (lever) or multi-directional. Fixing by the body.

520346

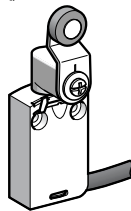

520347

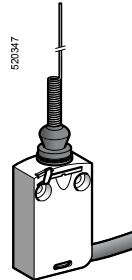

Page 5/11

5

■ XCM D
with integral connector

□ With head for linear movement (plunger)
Fixing by the body

Fixing by the head

561281

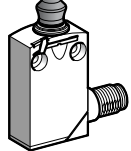

561282

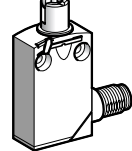

561283



Page 5/14

□ With head for rotary movement (lever) or multi-directional. Fixing by the body.

561284

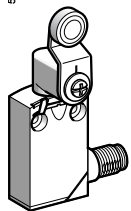

561285

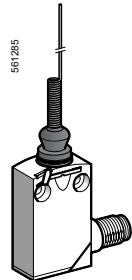

Page 5/15

Environment characteristics

Conforming to standards	Products	IEC 60947-5-1, EN 60947-5-1, UL 508, CSA C22-2 n° 14
	Machine assemblies	IEC 60204-1, EN 60204-1
Product certifications		UL, CSA (except products with special cables), CCC
Protective treatment		Standard version: "TC"
Ambient air temperature		Operation: - 25...+ 70 °C. Storage: - 40...+ 70 °C
Vibration resistance		XCM D snap action: 5 gn. XCM D slow break: 25 gn (10...500 Hz) conforming to IEC 60068-2-6
Shock resistance		25 gn (18 ms) conforming to IEC 60068-2-27
Electric shock protection		Class I conforming to IEC 61-140 and NF C 20-030
Degree of protection		IP 66, IP 67 and IP 68 (1) conforming to IEC 60529; IK 06 conforming to EN 50102
Materials		Bodies: zamak, heads: zamak
Repeat accuracy		0.05 mm on the tripping points, with 1 million operating cycles for head with end plunger

(1) Protection against prolonged immersion: the test conditions are subject to agreement between the manufacturer and the user.

Contact block characteristics

Rated operational characteristics	Switches with 2 contacts	~ AC-15; B300 (Ue = 240 V, Ie = 1.5 A) = DC-13; R300 (Ue = 250 V, Ie = 0.1 A), conforming to IEC 60947-5-1 Appendix A, EN 60947-5-1
	Switches with 3 and 4 contacts	~ AC-15; C300 (Ue = 240 V, Ie = 0.75 A) = DC-13; R300 (Ue = 250 V, Ie = 0.1 A), conforming to IEC 60947-5-1 Appendix A, EN 60947-5-1
	Pre-cabled switches	Ithe = 6 A for 2 contacts, 4 A for 3 contacts, 3 A for 4 contacts
	Switches with 4-pin M12 connector	Ui = 250 V, Ie = 3 A maximum, Ithe = 3 A
	Switches with 5-pin M12 connector	Ui = 60 V, Ie = 4 A maximum, Ithe = 4 A
	Switches with 5-pin 7/8" 16UN connector	Ui = 250 V, Ie = 6 A maximum, Ithe = 6 A
Rated insulation voltage		Ui = 400 V degree of pollution 3 conforming to IEC 60947-5-1 Ui = 300 V conforming to UL 508, CSA C22-2 n° 14
Rated impulse withstand voltage		U imp = 4 kV conforming to IEC 60947-1, IEC 60664
Positive operation (depending on model)		N/C contacts with positive opening operation conforming to IEC 60947-5-1 Appendix K, EN 60947-5-1
Resistance across terminals		≤ 25 mΩ conforming to IEC 60255-7 category 3
Electric shock protection		6 A cartridge fuse type gG (gl)
Minimum actuation speed		Snap action contact: 0.01 m/minute Slow break contact: 6 m/minute
Electrical durability		<ul style="list-style-type: none"> ■ Conforming to IEC 60947-5-1 Appendix C ■ Utilisation categories AC-15 and DC-13 ■ Maximum operating rate: 3600 operating cycles/hour ■ Load factor: 0.5

a.c. supply ~ 50/60 Hz
~m inductive circuit

XCM D snap action (N/C + N/O, N/C + N/C, N/C + N/C + N/O, N/C + N/C + N/O + N/O contacts)

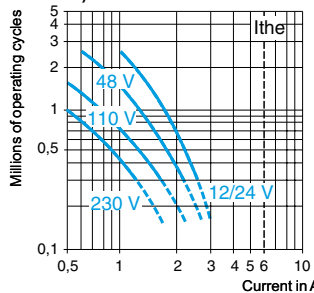

XCM D slow break (N/C + N/O, N/C + N/C + N/O contacts)

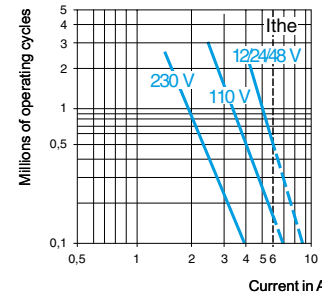

d.c. supply =

Power broken in W for 5 million operating cycles				
Voltage	V	24	48	120
~m	W	3	2	1

Power broken in W for 5 million operating cycles				
Voltage	V	24	48	120
~m	W	4	3	3

Type of head	Plunger (fixing by the body)				Plunger (fixing by the head)		
Type of operator	Metal end plunger	Metal end plunger with elastomer boot	Steel roller plunger	Retractable steel roller lever plunger	M12 with metal end plunger	M16 with metal end plunger with elastomer boot	M12 with steel roller plunger

References							
2-pole N/C + N/O snap action 	XCM D2110L1 	XCM D2111L1 	XCM D2102L1 	XCM D2124L1 	XCM D21F0L1 	XCM D21G1L1 	XCM D21F2L1
2-pole N/C + N/O break before make, slow break 	XCM D2510L1 	XCM D2511L1 	XCM D2502L1 	XCM D2524L1 	XCM D25F0L1 	XCM D25G1L1 	XCM D25F2L1
2-pole N/C + N/C snap action 	ZCM D29L1 + ZCE 10 	ZCM D29L1 + ZCE 11 	ZCM D29L1 + ZCE 02 	ZCM D29L1 + ZCE 24 	ZCM D29L1 + ZCE F0 	ZCM D29L1 + ZCE G1 	ZCM D29L1 + ZCE F2
3-pole N/C + N/C + N/O snap action 	ZCM D39L1 + ZCE 10 	ZCM D39L1 + ZCE 11 	ZCM D39L1 + ZCE 02 	ZCM D39L1 + ZCE 24 	ZCM D39L1 + ZCE F0 	ZCM D39L1 + ZCE G1 	ZCM D39L1 + ZCE F2
3-pole N/C + N/C + N/O break before make, slow break 	ZCM D37L1 + ZCE 10 	ZCM D37L1 + ZCE 11 	ZCM D37L1 + ZCE 02 	ZCM D37L1 + ZCE 24 	ZCM D37L1 + ZCE F0 	ZCM D37L1 + ZCE G1 	ZCM D37L1 + ZCE F2
Weight (kg)	0.180	0.180	0.185	0.200	0.195	0.220	0.205
4-pole N/C + N/C + N/O + N/O snap action 	ZCM D41L1 + ZCE 10 	ZCM D41L1 + ZCE 11 	ZCM D41L1 + ZCE 02 	ZCM D41L1 + ZCE 24 	ZCM D41L1 + ZCE F0 	ZCM D41L1 + ZCE G1 	ZCM D41L1 + ZCE F2
Weight (kg)	0.160	0.160	0.165	0.180	0.175	0.200	0.185
Contact operation			(A) = cam displacement				
			(P) = positive opening point				

Characteristics							
Switch actuation	On end	By 30° cam			On end	By 30° cam	
Type of actuation							
Maximum actuation speed	0.5 m/s						0.1 m/s
Mechanical durability	10 million operating cycles						
Minimum force or torque	For tripping	8.5 N	7 N	2.5 N	8.5 N	7 N	7 N
	For positive opening	42.5 N	35 N	12.5 N	42.5 N	35 N	35 N
Cabling	PvR cable; 5 x 0.75 mm ² , length 1 metre for 2-pole contact versions, 7 x 0.5 mm ² , length 1 metre for 3-pole contact versions, 9 x 0.34 mm ² , length 1 metre for 4-pole contact versions. For other cable lengths, see page 5/22.						

5

Limit switches

Osiswitch® Universal, Osiconcept®
Miniature design, metal, type XCM D
Pre-cabled

Type of head	Rotary (fixing by the body)				Multi-directional
Type of operator	Thermoplastic roller lever	Steel roller lever	Roller lever with ball bearing mounted roller	Variable length thermoplastic roller lever	"Cat's whisker" (1)
References					
2-pole N/C + N/O snap action	XCM D2115L1 	XCM D2116L1 	XCM D2117L1 	XCM D2145L1 	XCM D2106L1
2-pole N/C + N/O break before make, slow break	XCM D2515L1 	XCM D2516L1 	XCM D2517L1 	XCM D2545L1 	XCM D2506L1
2-pole N/C + N/C snap action	ZCM D29L1 + ZCE 01 + ZCY 15 	ZCM D29L1 + ZCE 01 + ZCY 16 	ZCM D29L1 + ZCE 01 + ZCY 17 	ZCM D29L1 + ZCE 01 + ZCY 45 	ZCM D29L1 + ZCE 06
3-pole N/C + N/C + N/O snap action	ZCM D39L1 + ZCE 01 + ZCY 15 	ZCM D39L1 + ZCE 01 + ZCY 16 	ZCM D39L1 + ZCE 01 + ZCY 17 	ZCM D39L1 + ZCE 01 + ZCY 45 	ZCM D39L1 + ZCE 06
3-pole N/C + N/C + N/O break before make, slow break	ZCM D37L1 + ZCE 01 + ZCY 15 	ZCM D37L1 + ZCE 01 + ZCY 16 	ZCM D37L1 + ZCE 01 + ZCY 17 	ZCM D37L1 + ZCE 01 + ZCY 45 	ZCM D37L1 + ZCE 06
Weight (kg)	0.220	0.225	0.220	0.230	0.180
4-pole N/C + N/C + N/O + N/O snap action	ZCM D41L1 + ZCE 01 + ZCY 15 	ZCM D41L1 + ZCE 01 + ZCY 16 	ZCM D41L1 + ZCE 01 + ZCY 17 	ZCM D41L1 + ZCE 01 + ZCY 45 	ZCM D41L1 + ZCE 06
Weight (kg)	0.200	0.205	0.200	0.210	0.160
Contact operation	 (A) = cam displacement (P) = positive opening point (1) Value taken with actuation by moving part at 100 mm from the fixings.				
Characteristics					
Switch actuation	By 30° cam				By any moving part
Type of actuation					
Maximum actuation speed	1.5 m/s				1 m/s
Mechanical durability	10 million operating cycles				5
Minimum force or torque	For tripping	0.1 N.m			
	For positive opening	0.5 N.m			
Cabling	PvR cable; 5 x 0.75 mm ² , length 1 metre for 2-pole contact versions, 7 x 0.5 mm ² , length 1 metre for 3-pole contact versions, 9 x 0.34 mm ² , length 1 metre for 4-pole contact versions. For other cable lengths, see page 5/22.				

Limit switches

Osiswitch® Universal, Osiconcept®

Miniature design, metal, type XCM D

Pre-cabled

XCM D2•10L1

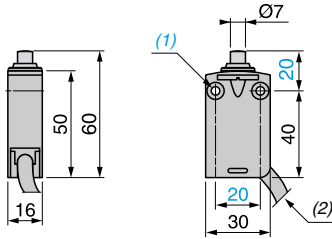

XCM D2•11L1

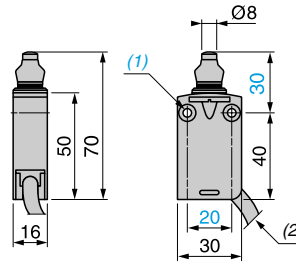

XCM D2•02L1

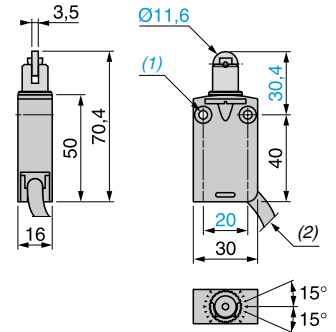

XCM D2•24L1

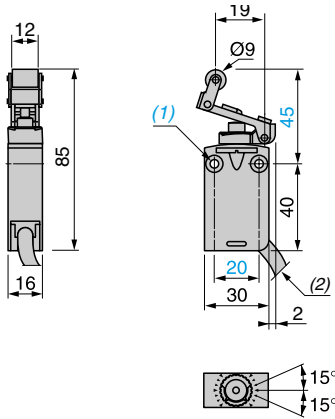

XCM D2•F0L1

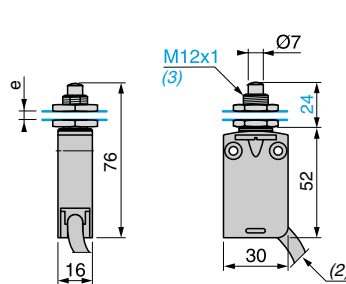

XCM D2•G1L1

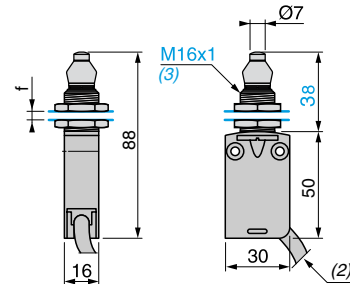

XCM D2•F2L1

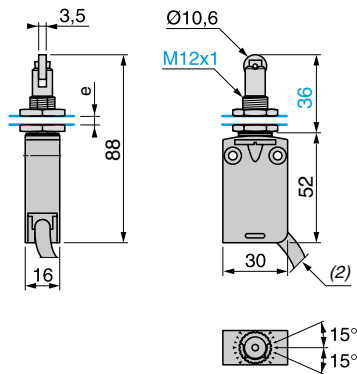

(1) 2 fixing holes \varnothing 4.2 mm, counterbored \varnothing 8 mm by 4 mm deep.

(2) Overall diameter of cable 7.5 mm.

(3) Fixing nut thickness 3.5 mm.

e: 8 mm max, panel cut-out \varnothing 12.5 mm.

f: 8 mm max, panel cut-out \varnothing 16.5 mm.

Limit switches

Osiswitch® Universal, Osiconcept®
Miniature design, metal, type XCM D
Pre-cabled

XCM D2•15L1

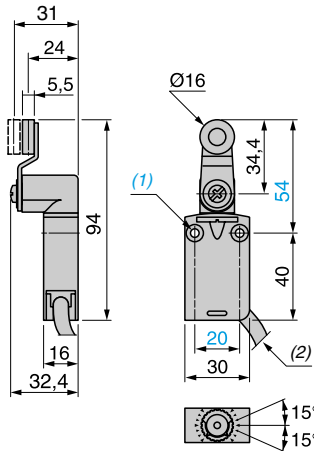

XCM D2•16L1

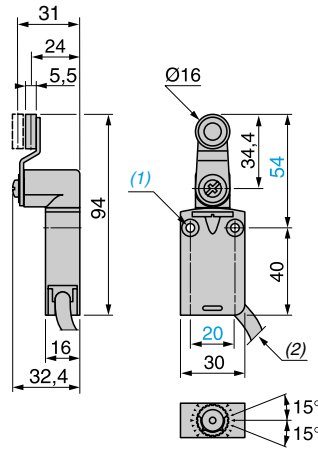

XCM D2•17L1

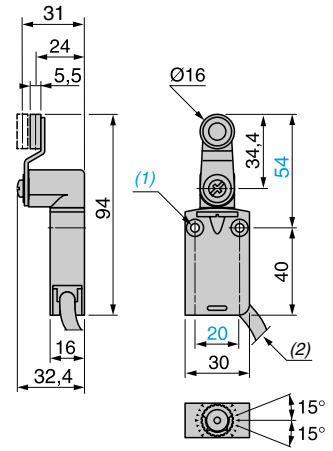

XCM D2•45L1

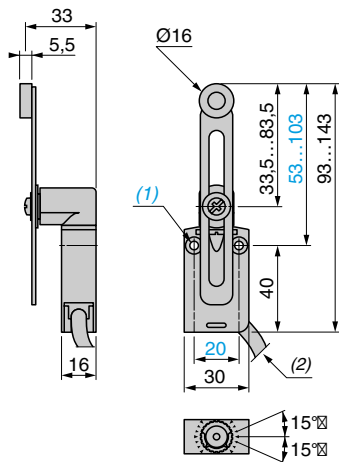

XCM D2•06L1

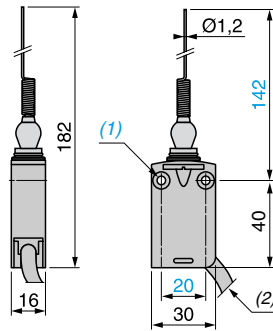

(1) 2 fixing holes \varnothing 4.2 mm, counterbored \varnothing 8 mm by 4 mm deep.
(2) Overall diameter of cable 7.5 mm.
e: 8 mm max, panel cut-out \varnothing 12.5 mm.
f: 8 mm max, panel cut-out \varnothing 16.5 mm.

Limit switches

Osiswitch® Universal, Osiconcept®

Miniature design, metal, type XCM D

Integral or remote connector

Type of head	Plunger (fixing by the body)				Plunger (fixing by the head)		
Type of operator	Metal end plunger	Metal end plunger with elastomer boot	Steel roller plunger	Retractable steel roller lever plunger	M12 with metal end plunger	M16 with metal end plunger with elastomer boot	M12 with steel roller plunger

References							
	XCM D2110M12	XCM D2111M12	XCM D2102M12	XCM D2124M12	XCM D21F0M12	XCM D21G1M12	XCM D21F2M12
	XCM D2110C12	XCM D2111C12	XCM D2102C12	XCM D2124C12	XCM D21F0C12	XCM D21G1C12	XCM D21F2C12
	ZCM D29C12 + ZCE 10	ZCM D29C12 + ZCE 11	ZCM D29C12 + ZCE 02	ZCM D29C12 + ZCE 24	ZCM D29C12 + ZCE F0	ZCM D29C12 + ZCE G1	ZCM D29C12 + ZCE F2
Weight (kg)	0.085	0.085	0.090	0.105	0.100	0.125	0.110
	ZCM D21L08R12 + ZCE 10	ZCM D21L08R12 + ZCE 11	ZCM D21L08R12 + ZCE 02	ZCM D21L08R12 + ZCE 24	ZCM D21L08R12 + ZCE F0	ZCM D21L08R12 + ZCE G1	ZCM D21L08R12 + ZCE F2
	ZCM D21L08U78 + ZCE 10	ZCM D21L08U78 + ZCE 11	ZCM D21L08U78 + ZCE 02	ZCM D21L08U78 + ZCE 24	ZCM D21L08U78 + ZCE F0	ZCM D21L08U78 + ZCE G1	ZCM D21L08U78 + ZCE F2
Weight (kg)	0.150	0.150	0.155	0.170	0.165	0.190	0.175
Contact operation	contact closed contact open		(A) = cam displacement		N/C contact with positive opening operation (P) = positive opening point		

Characteristics						
Switch actuation	On end	By 30° cam		On end	By 30° cam	
Type of actuation						
Maximum actuation speed	0.5 m/s				0.1 m/s	
Mechanical durability	10 million operating cycles					
Minimum force or torque	For tripping	8.5 N	7 N	2.5 N	8.5 N	7 N
	For positive opening	42.5 N	35 N	12.5 N	42.5 N	35 N
Positive operation	Although their design is identical to the pre-cabled switches, the switches incorporating an M12 4-pin connector cannot be marked with the because they are single-pole C/O.					

5

Limit switches

Osiswitch® Universal, Osiconcept®
Miniature design, metal, type XCM D
Integral or remote connector

Type of head	Rotary (fixing by the body)				Multi-directional
Type of operator	Thermoplastic roller lever	Steel roller lever	Roller lever with ball bearing mounted roller	Variable length thermoplastic roller lever	"Cat's whisker" (1)
References					
 Single-pole C/O snap action With integral M12 4-pin connector	XCM D2115M12 	XCM D2116M12 	XCM D2117M12 	XCM D2145M12 	XCM D2106M12
 2-pole N/C + N/O snap action With integral M12 5-pin connector	XCM D2115C12 	XCM D2116C12 	XCM D2117C12 	XCM D2145C12 	XCM D2106C12
 2-pole N/C + N/C snap action With integral M12 5-pin connector	ZCM D29C12 + ZCE 01 + ZCY 15 	ZCM D29C12 + ZCE 01 + ZCY 16 	ZCM D29C12 + ZCE 01 + ZCY 17 	ZCM D29C12 + ZCE 01 + ZCY 45 	ZCM D29C12 + ZCE 06
 2-pole N/C + N/O snap action With M12 5-pin connector on 0.8 m flying lead	ZCM D21L08R12 + ZCE 01 + ZCY 15 	ZCM D21L08R12 + ZCE 01 + ZCY 16 	ZCM D21L08R12 + ZCE 01 + ZCY 17 	ZCM D21L08R12 + ZCE 01 + ZCY 45 	ZCM D21L08R12 + ZCE 06
 2-pole N/C + N/O snap action With 7/8" 16UN 5-pin connector on 0.8 m flying lead	ZCM D21L08U78 + ZCE 01 + ZCY 15 	ZCM D21L08U78 + ZCE 01 + ZCY 16 	ZCM D21L08U78 + ZCE 01 + ZCY 17 	ZCM D21L08U78 + ZCE 01 + ZCY 45 	ZCM D21L08U78 + ZCE 06
Weight (kg)	0.125	0.130	0.125	0.135	0.085
Contact operation	 (A) = cam displacement (P) = positive opening point ⊕ N/C contact with positive opening operation				

(1) Value taken with actuation by moving part at 100 mm from the fixing.

Characteristics			
Switch actuation	By 30° cam	By any moving part	
Type of actuation			
Maximum actuation speed	1.5 m/s	1 m/s	
Mechanical durability	10 million operating cycles	5	
Minimum force or torque	For tripping For positive opening	0.1 N.m 0.5 N.m	-
Positive operation	Although their design is identical to the pre-cabled switches, the switches incorporating an M12 4-pin connector cannot be marked with the ⊕ symbol because they are single-pole C/O.		

References of suitable pre-wired female connectors

Type of connector	M12 straight, 4-pin 4 A, 250 V	M12 straight, 5-pin 4 A, 24 V	M12 elbowed, 5-pin 4 A, 24 V	7/8" 16 UN straight, 5-pin, 6 A, 250 V
With cable	L = 2 m	XZ CP1169L2	XZ CP1164L2	XZ CP1264L2
	L = 5 m	XZ CP1169L5	XZ CP1164L5	XZ CP1264L5
	L = 10 m	XZ CP1169L10	XZ CP1164L10	XZ CP1264L10
Weight (kg)	0.105	0.115	0.115	0.190

Connections

XCM D with connector

4-pin, M12

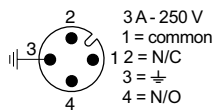

5-pin, M12

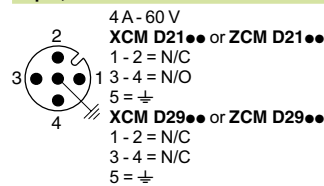

5-pin, 7/8" 16 UN

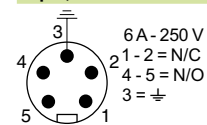

Pre-wired female connectors XZ CP

4-pin, M12

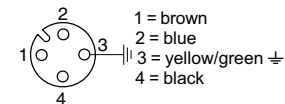

5-pin, M12

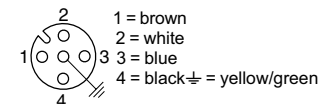

5-pin, 7/8" 16 UN

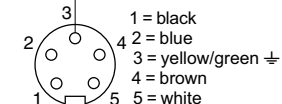

5

Dimensions

XZ CP116L

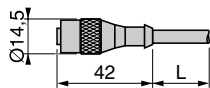

XZ CP1264L

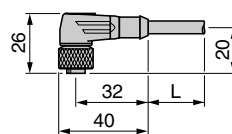

XZ CP1771L

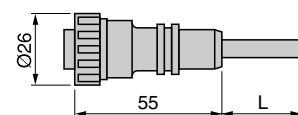

L: cable length 2, 5 or 10 m.

Distances required for plug-in connectors

M12 straight connector

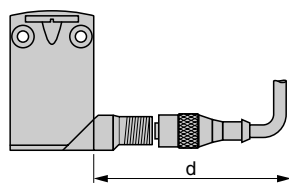

d: min. 65 mm, recommended 69 mm.

M12 elbowed connector

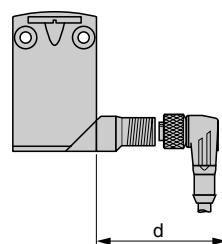

d: min. 42 mm, recommended 45 mm.

Connector on flying lead

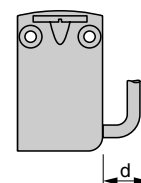

d: min. 20 mm.

Limit switches

Osiswitch® Universal, Osiconcept®

Miniature design, metal, type XCM D

Integral or remote connector

XCM D2•10M12

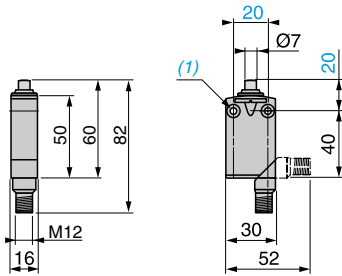

XCM D2•11M12

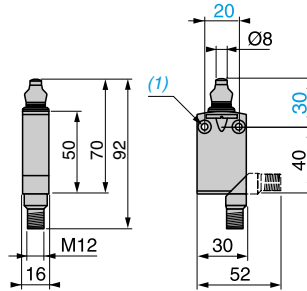

XCM D2•02M12

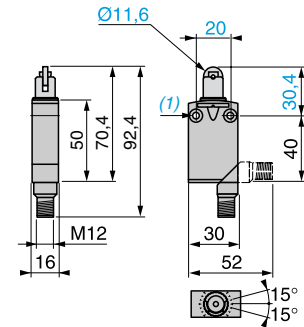

XCM D2•24M12

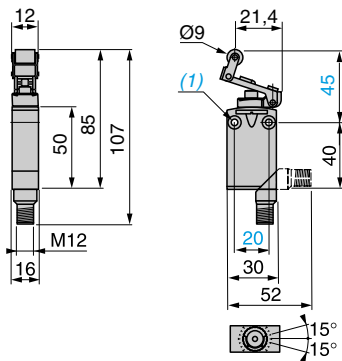

XCM D2•F0M12

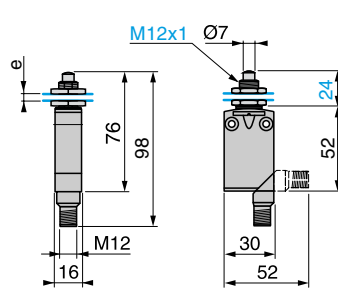

XCM D2•G1M12

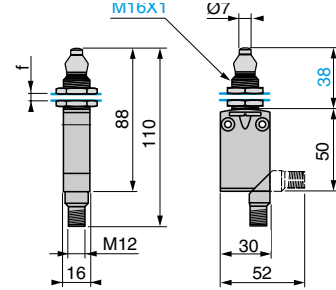

XCM D2•F2M12

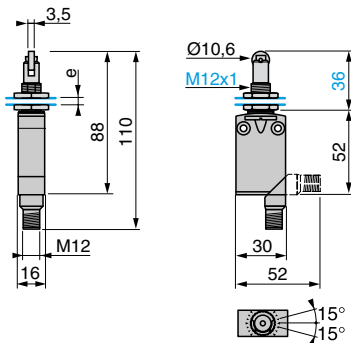

XCM D2•45M12

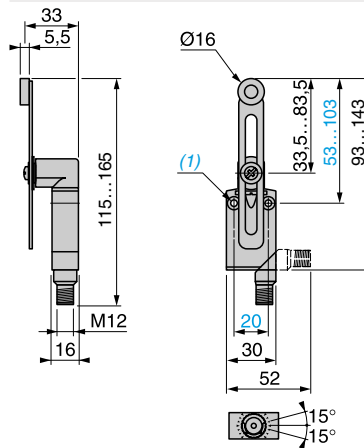

XCM D2•15M12 /•16M12 /•17M12

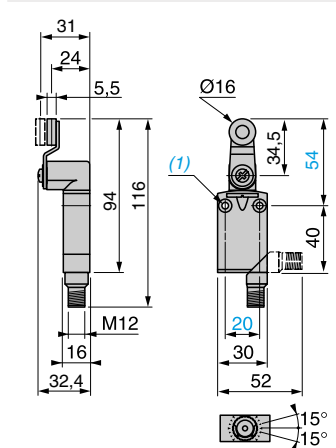

XCM D2•06M12

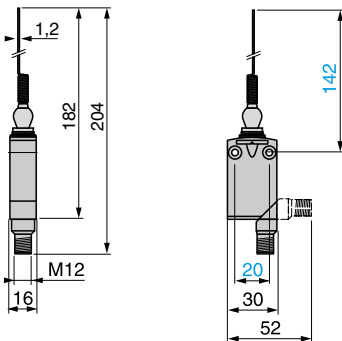

(1) 2 fixing holes Ø 4.2 mm, counterbored Ø 8 mm by 4 mm deep.
e: 8 mm max., panel cut-out Ø 12.5 mm, fixing nut thickness 3.5 mm.
f: 8 mm max., panel cut-out Ø 16.5 mm, fixing nut thickness 3.5 mm.

Limit switches

Osiswitch® Universal, Osiconcept®

Miniature design, metal, type XCM D

Integral or remote connector

ZCM D21L08... + ZCE 10

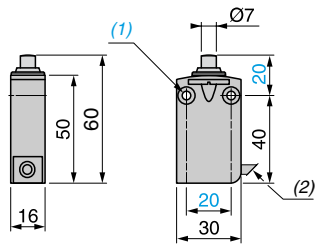

ZCM D21L08... + ZCE 11

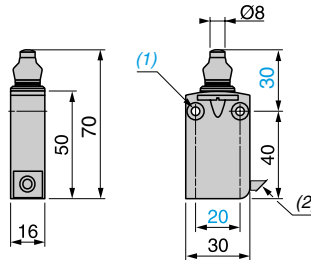

ZCM D21L08... + ZCE 02

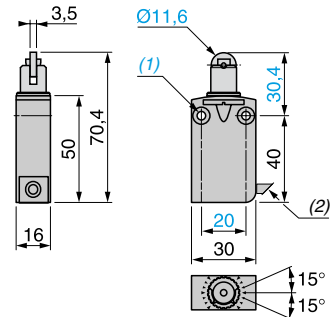

ZCM D21L08... + ZCE 24

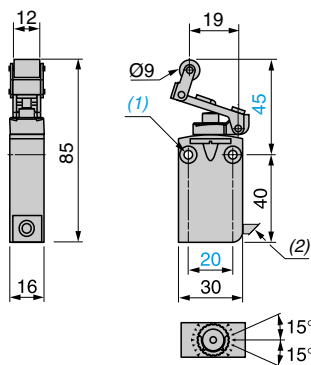

ZCM D21L08... + ZCE F0

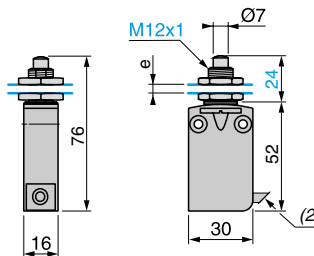

ZCM D21L08... + ZCE G1

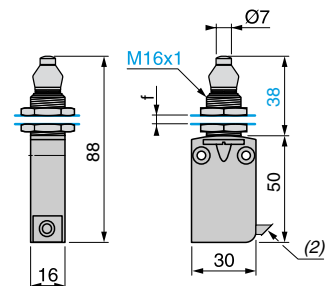

5

(1) 2 fixing holes $\varnothing 4.2$ mm, counterbored $\varnothing 8$ mm by 4 mm deep.

(2) Overall diameter 7.5 mm.

e: 8 mm max., panel cut-out $\varnothing 12.5$ mm, fixing nut thickness 3.5 mm.

f: 8 mm max., panel cut-out $\varnothing 16.5$ mm, fixing nut thickness 3.5 mm.

Limit switches

Osiswitch® Universal, Osiconcept®
 Miniature design, metal, type XCM D
 Integral or remote connector

ZCM D21L08... + ZCE F2

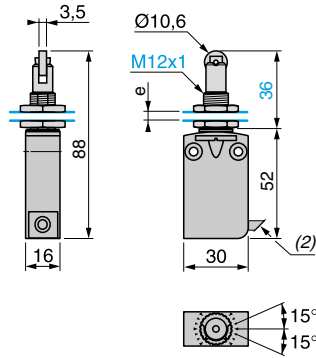

ZCM D21L08... + ZCE 01
 + ZCY 15/16/17

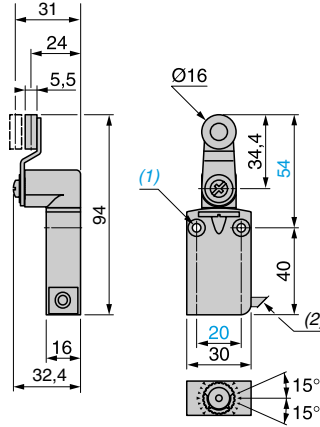

ZCM D21L08... + ZCE 01 + ZCY 45

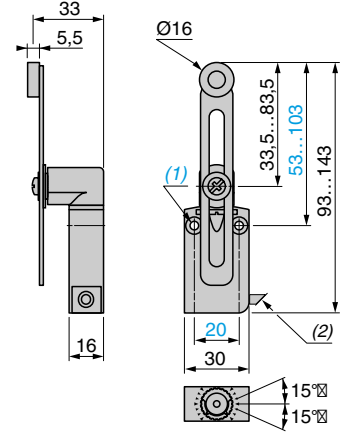

ZCM D21L08... + ZCE 06

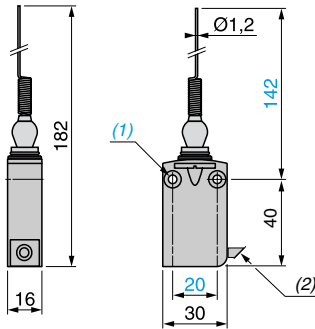

(1) 2 fixing holes \varnothing 4.2 mm, counterbored \varnothing 8 mm by 4 mm deep.
 (2) Overall diameter 7.5 mm.
 e: 8 mm max., panel cut-out \varnothing 12.5 mm, fixing nut thickness 3.5 mm.
 f: 8 mm max., panel cut-out \varnothing 16.5 mm, fixing nut thickness 3.5 mm.

Limit switches

Osiswitch® Universel, Osiconcept®

Miniature design, metal, type XCM D

Variable composition

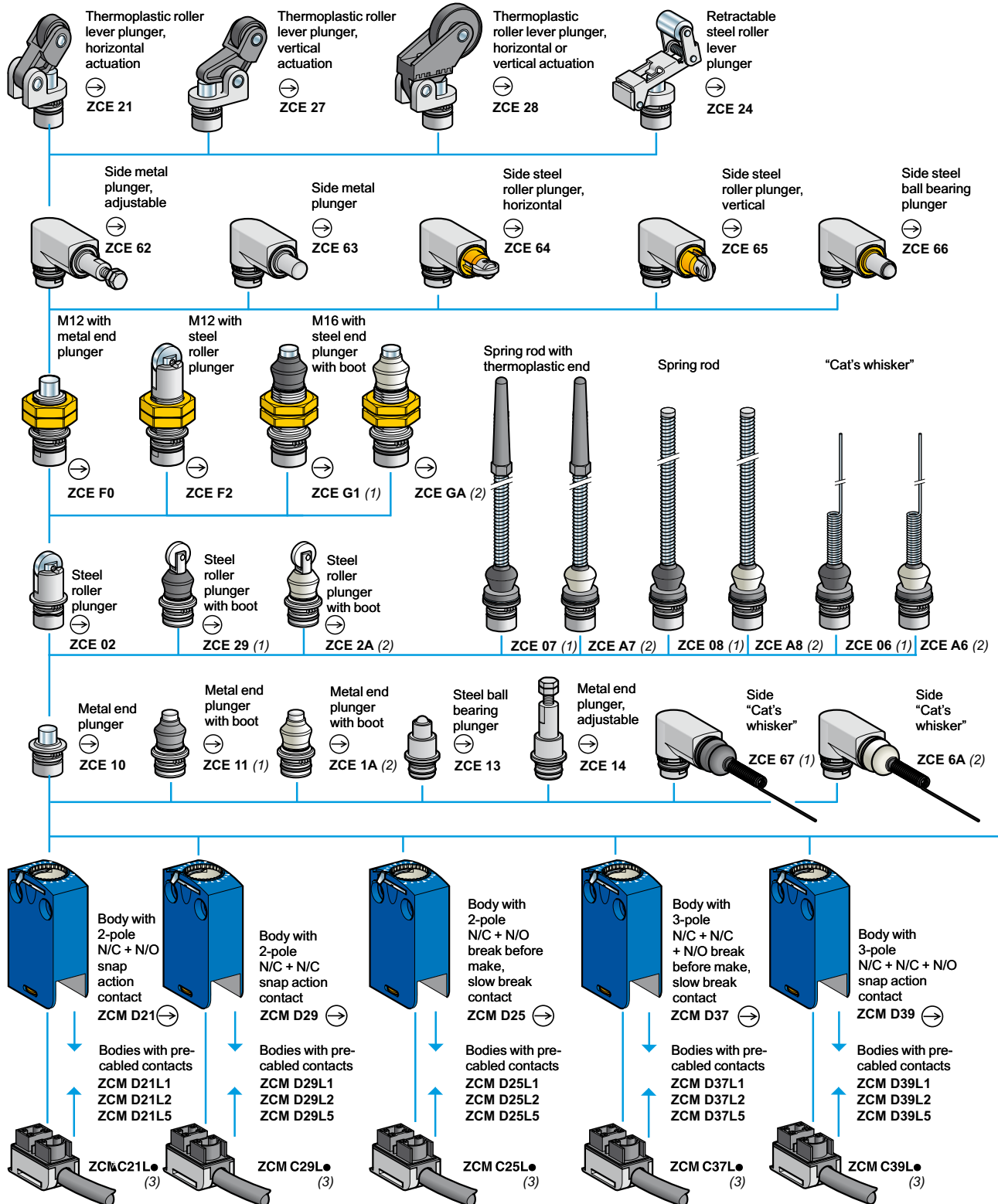

(1) Nitrile boot for indoor use.

(2) Silicone boot for outdoor use.

(3) Pre-cabled connection components: replace the "●" in the reference by the required cable length in metres, either: 1, 2, 3, 5, 7 or 10.

Example: ZCM C21L● becomes ZCM C21L7 for a 7 metre long cable.

Note: only cable lengths of 1, 2 and 5 metres are available for pre-cabled connection components ZCM C37L● and ZCM C39L●.

ERROR: rangecheck
OFFENDING COMMAND: .buildshading2

STACK:

-dictionary-
-dictionary-
-savelevel-